

PRODUCT NO.
93764-4****

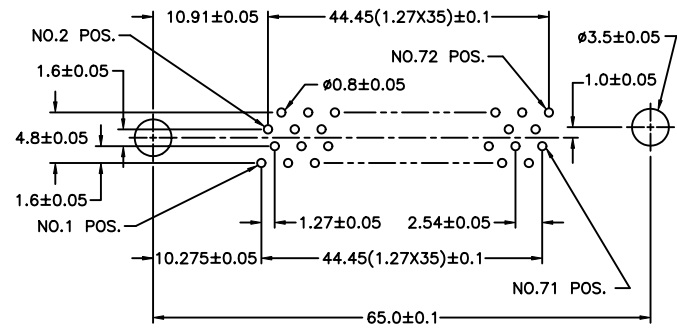

RECOMMENDED PCB LAYOUT

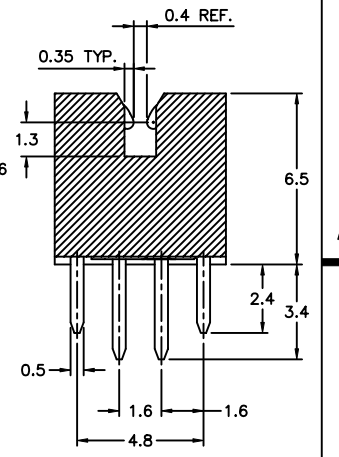
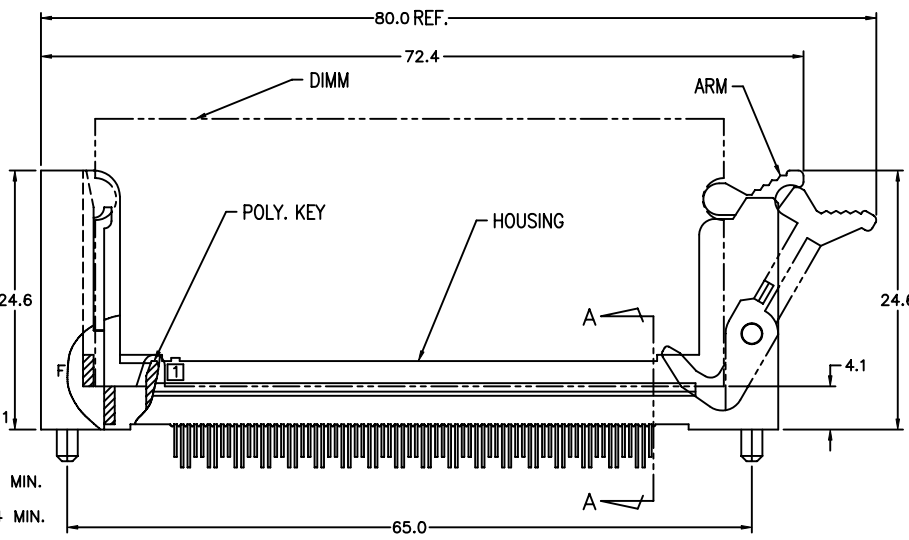
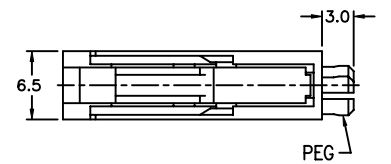
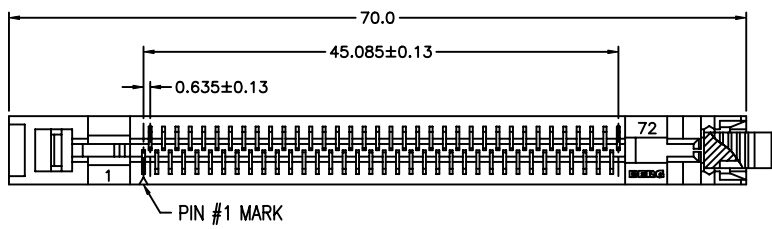

SECT. A-A
SCALE 5:1

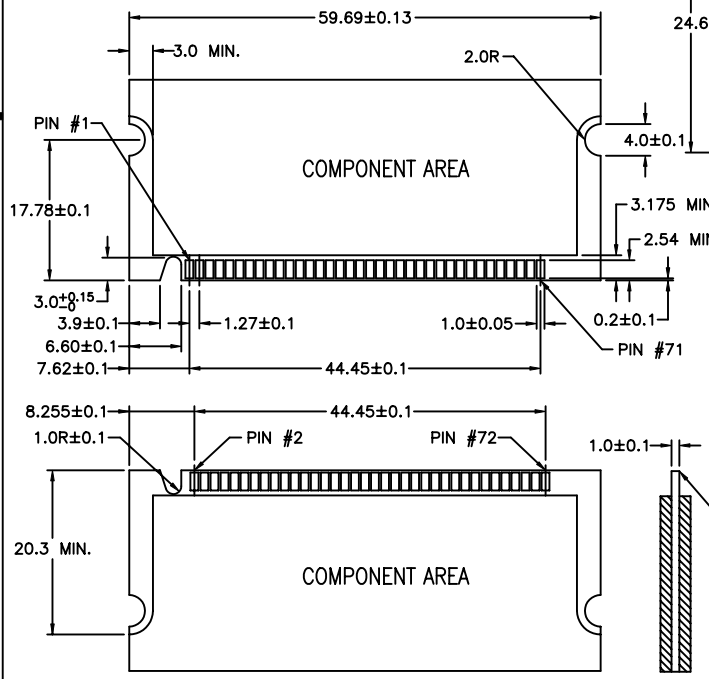

RECOMMENDED DIMM LAYOUT

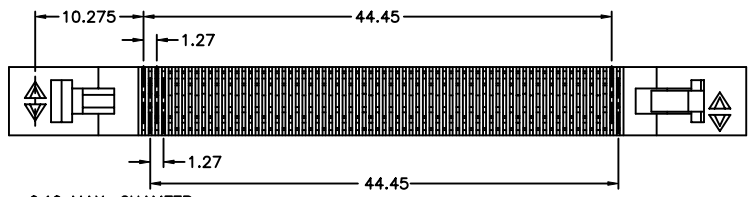

CONFIDENTIAL

mat'l. code				tolerances unless otherwise specified				CUSTOMER COPY				 www.fciconnect.com title SMALL OUTLINE DIMM SOCKET VERTICAL TYPE ASS'Y product family S.O.DIMM code - size dwg no 93764 sheet 1 of 12			
ltr	ecn no	dr	date	linear	.X ± 0.20	projection									
U	T05-0053	R C	03/11/05		.XX ± 0.10	 MM scale 1.5:1									
M	T90167	M W	04/26/99		.XXX ±										
N	T00078	M W	03/20/00	angles	0° ±2°										
P	T00056	M W	04/10/00	dr	CATHY LIN	02/13/95									
R	T20015	M W	02/06/02	engr	V. CHUANG	02/13/95									
S	T20102	M W	04/11/02	chr	WAYNE YU	02/13/95									
T	T03-0425	M W	09/24/03	appd	D K WANG	02/13/95									
sheet	revision	U	T	T	T	T	T	T	T	T	U				
index	sheet	1	2	3	4	5	6	7	8	9	10	11	12		

Tous droits strictement reserves. Reproduction ou communication a des tiers interdite sous quelque forme que ce soit sans autorisation ecrite du proprietaire. Propriete de c FCI. Droits de reproduction FCI.

All rights strictly reserved. Reproduction or issue to third parties in any form whatever is not permitted without written authority from the proprietor. Property of FCI. Copyright FCI.

All rights strictly reserved. Reproduction or issue to third parties in any form whatever is not permitted without written authority from the proprietor. Property of FCI. Copyright FCI.
 Tous droits strictement réservés. Reproduction ou communication à des tiers interdite sous quelque forme que ce soit sans autorisation écrite du propriétaire. Propriété de c FCI. Droits de reproduction FCI.

PRODUCT NO.
93764-5****

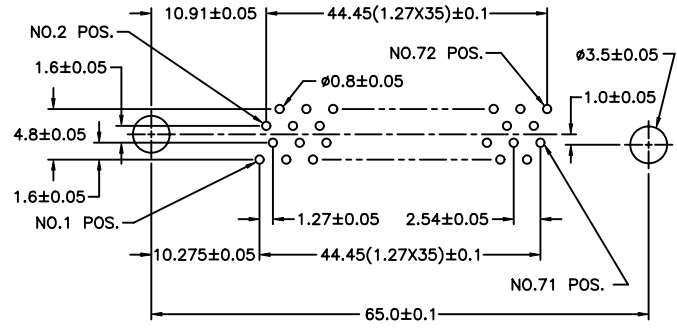

RECOMMENDED PCB LAYOUT

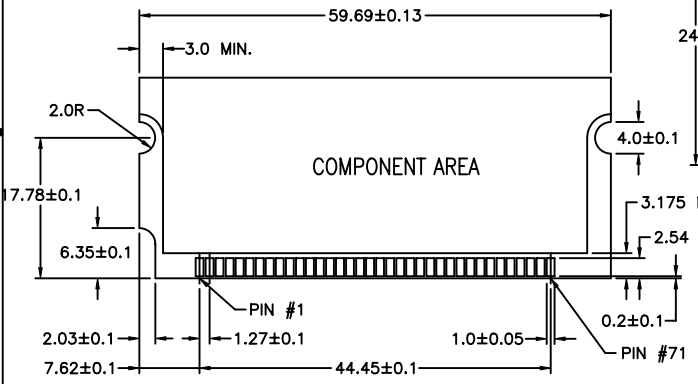

RECOMMENDED DIMM LAYOUT

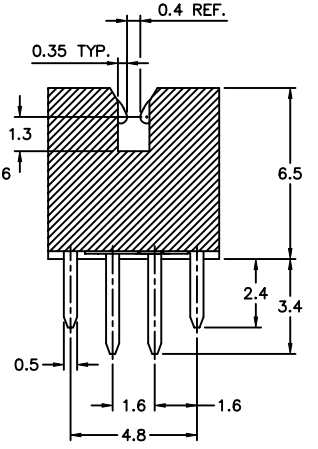
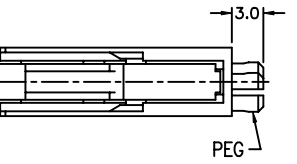
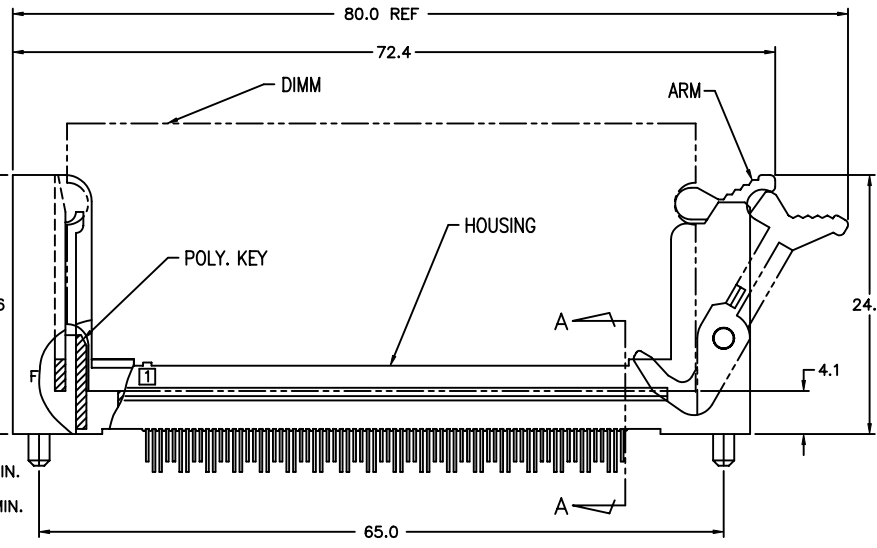
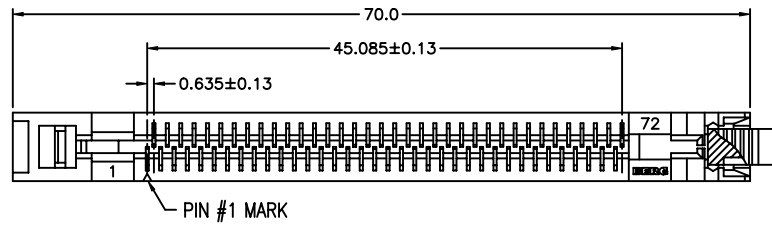

SECT. A-A
SCALE 5:1

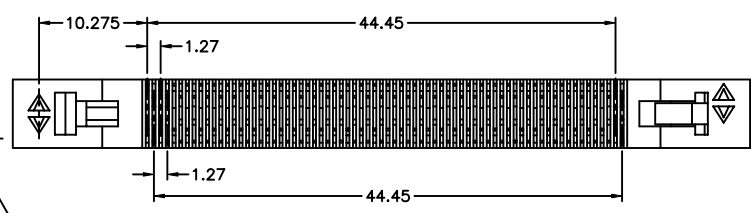

CONFIDENTIAL

mat'l. code				tolerances unless otherwise specified		CUSTOMER COPY		 www.fciconnect.com			
ltr	ecn no	dr	date	linear	.X ± 0.20	projection	title				
T					.XX ± 0.10	 MM	SMALL OUTLINE DIMM SOCKET VERTICAL TYPE ASS'Y	product family	S.O.DIMM	code	-
				angles	.XXX ±		scale	size	dwg no		sheet
					0° ±2°	1.5:1	A4	93764			
sheet index	revision sheet										

Tous droits strictement reserves. Reproduction ou communication a des tiers interdite sous quelque forme que ce soit sans autorisation ecrite du proprietaire. Propriete de c FCI. Droits de reproduction FCI.

All rights strictly reserved. Reproduction or issue to third parties in any form whatever is not permitted without written authority from the proprietor. Property of FCI. Copyright FCI.

PRODUCT NO.
93764-3****

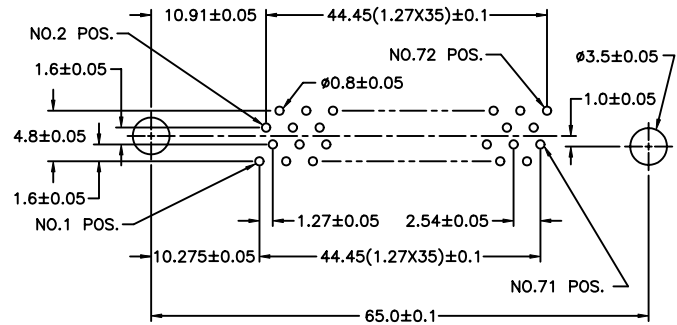

RECOMMENDED PCB LAYOUT

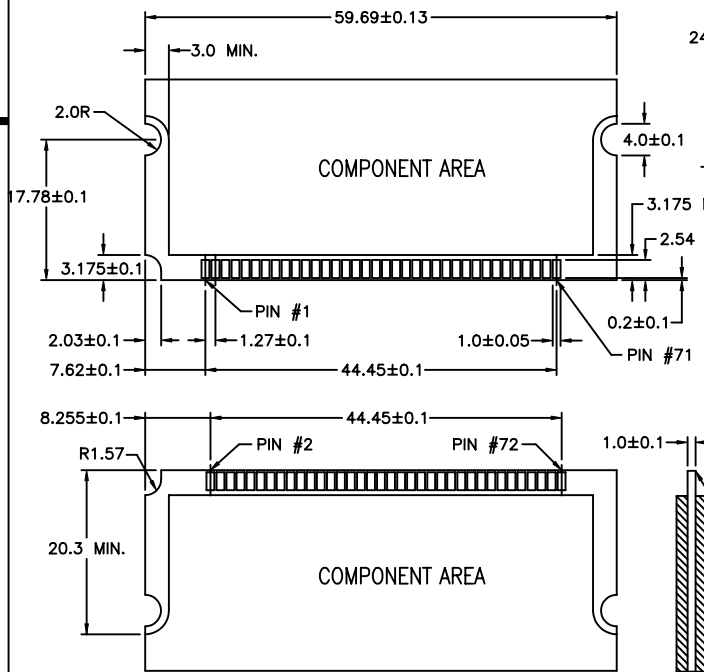

RECOMMENDED DIMM LAYOUT

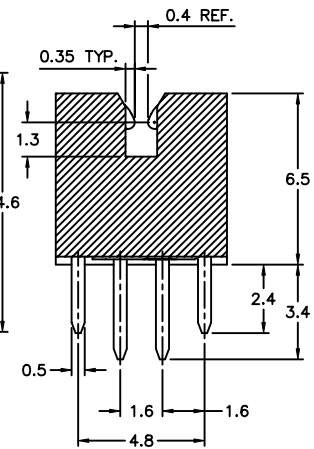
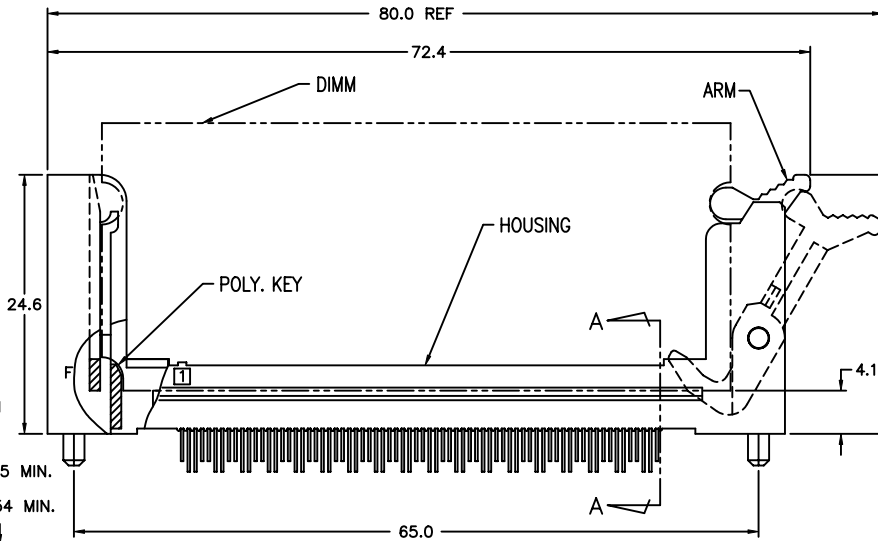
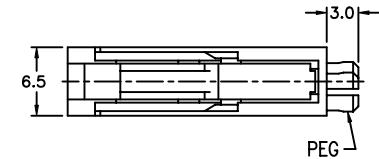
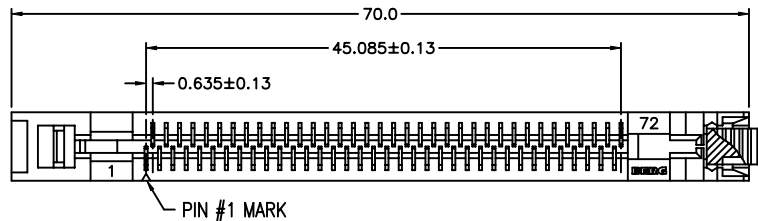

SECT. A-A
SCALE 5:1

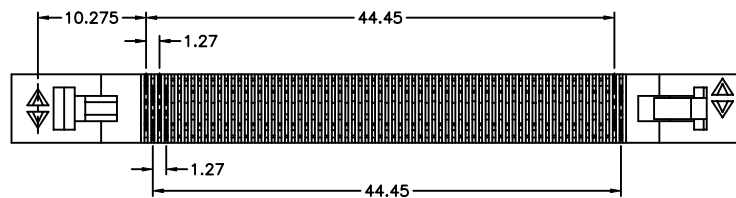

CONFIDENTIAL

mat'l. code		tolerances unless otherwise specified		CUSTOMER COPY		 www.fciconnect.com	
ltr	ecn no	dr	date	linear	.X ± 0.20	projection	title
T					.XX ± 0.10		SMALL OUTLINE DIMM SOCKET VERTICAL TYPE ASS'Y
				angles	.XXX ±		product family
					0° ±2°	scale	code
				dr	CATHY LIN 02/13/95	1.5:1	-
				enr	V. CHUANG 02/13/95	size	dwg no
				chr	WAYNE YU 02/13/95	A4	93764
				appd	D K WANG 02/13/95	sheet	3 of
sheet index	revision sheet						

All rights strictly reserved. Reproduction or issue to third parties in any form whatever is not permitted without written authority from the proprietor. Property of FCI. Copyright FCI.
 Tous droits strictement réservés. Reproduction ou communication à des tiers interdite sous quelque forme que ce soit sans autorisation écrite du propriétaire. Propriété de c FCI. Droits de reproduction FCI.

PRODUCT NO.
93764-7****

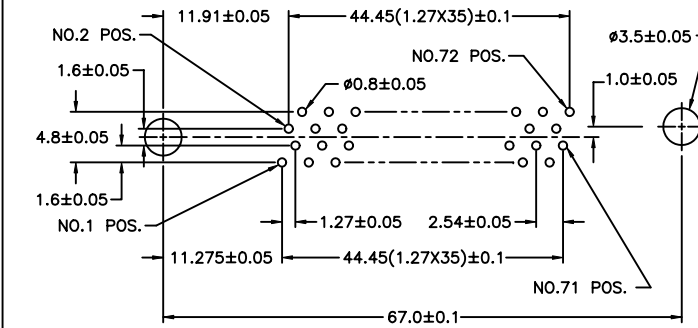

RECOMMENDED PCB LAYOUT

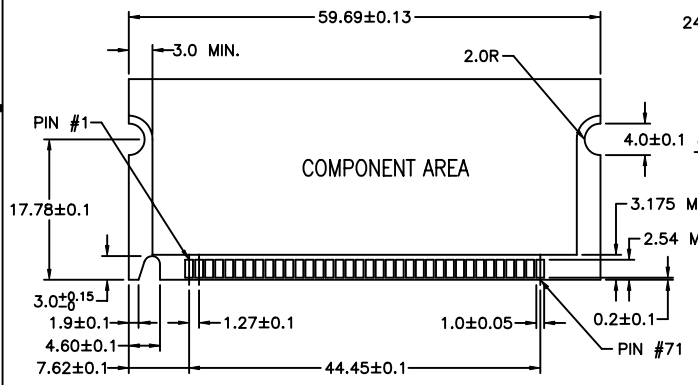

RECOMMENDED DIMM LAYOUT

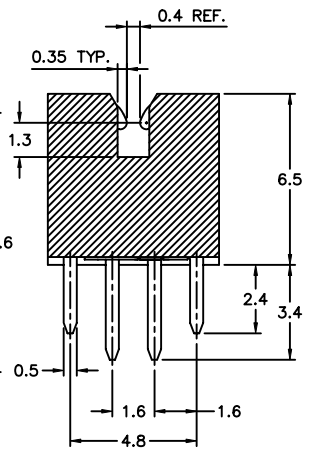
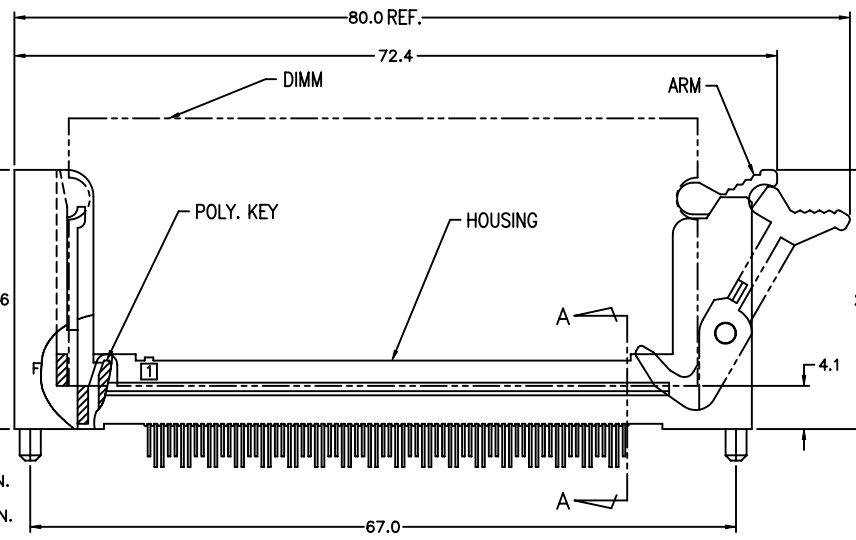
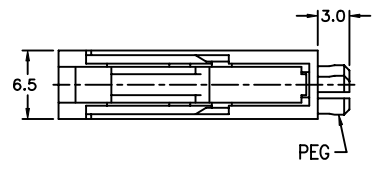
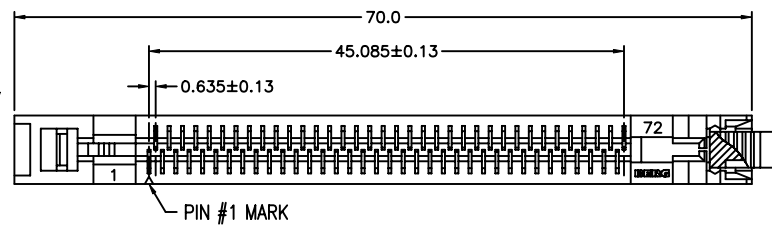

SECTION A-A
SCALE 5:1

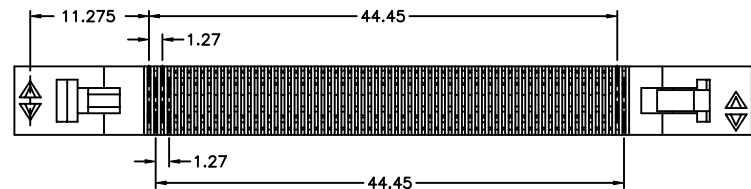

CONFIDENTIAL

mat'l. code				tolerances unless otherwise specified			CUSTOMER COPY		 www.fciconnect.com	
ltr	ecn no	dr	date	linear	.X ± 0.20	projection	title			
T					.XX ± 0.10		SMALL OUTLINE DIMM SOCKET VERTICAL TYPE ASS'Y			
				angles	.XXX ±		product family	S.O.DIMM		code
					0° ±2°	MM	size	dwg no		sheet
				dr	CATHY LIN 02/13/95	scale	93764		4 of	
				engr	V. CHUANG 02/13/95	1.5:1				
				chr	WAYNE YU 02/13/95					
				appd	D K WANG 02/13/95					
sheet index	revision sheet									

Tous droits strictement reserves. Reproduction ou communication a des tiers interdite sous quelque forme que ce soit sans autorisation écrite du propriétaire. Propriete de c FCI. Droits de reproduction FCI.

All rights strictly reserved. Reproduction or issue to third parties in any form whatever is not permitted without written authority from the proprietor. Property of FCI. Copyright FCI.

PRODUCT NO.
93764-8****

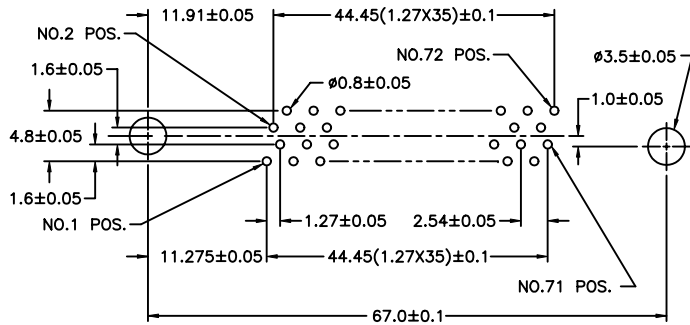

RECOMMENDED PCB LAYOUT

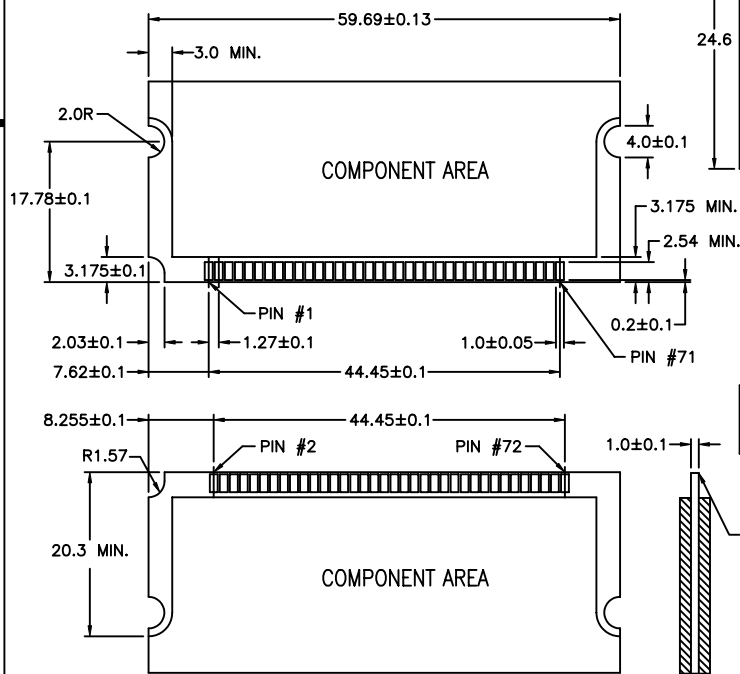

RECOMMENDED DIMM LAYOUT

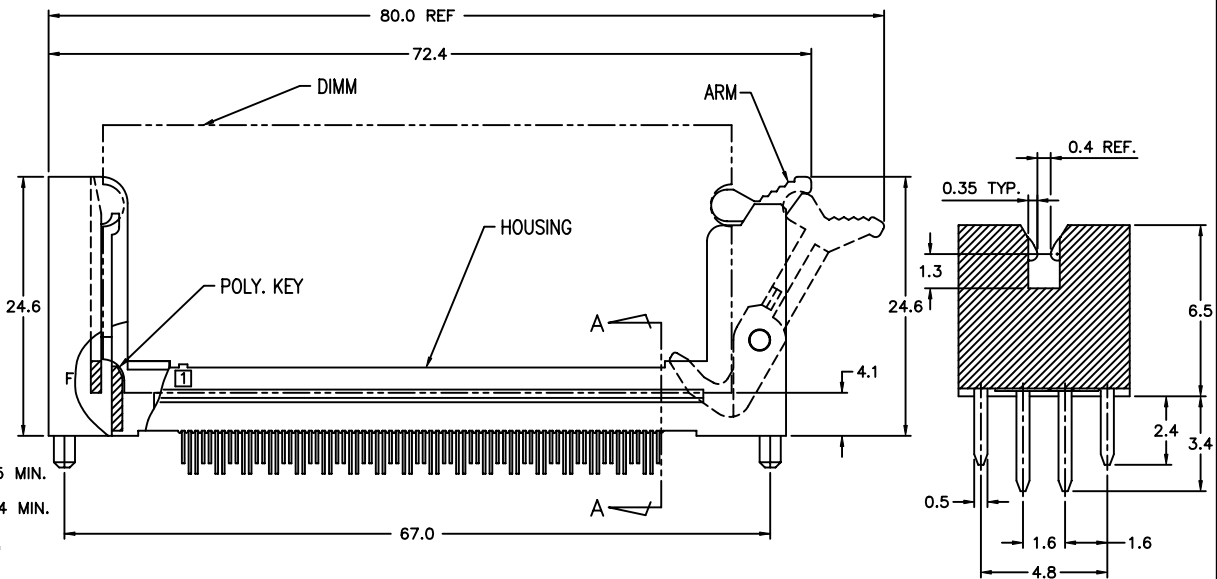
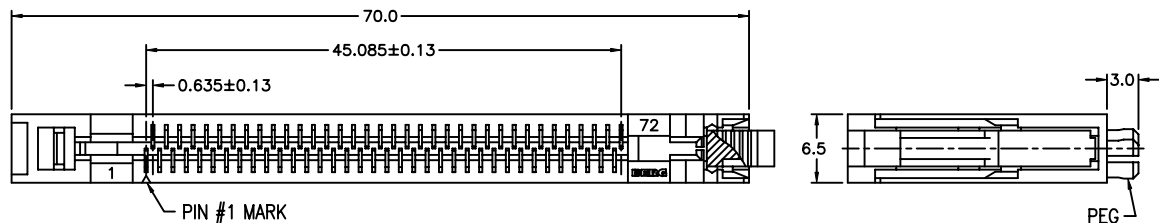

SECT. A-A
SCALE 5:1

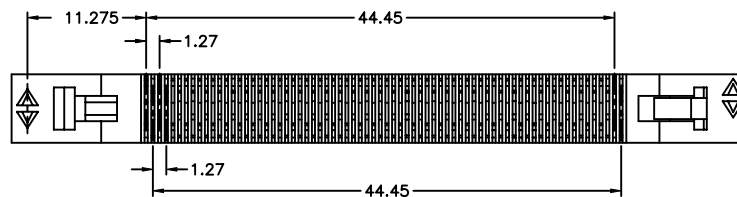

CONFIDENTIAL

mat'l. code				tolerances unless otherwise specified		CUSTOMER COPY		FCI www.fciconnect.com	
ltr	ecn no	dr	date	linear	.X ± 0.20	projection	title		
T					.XX ± 0.10		SMALL OUTLINE DIMM SOCKET VERTICAL TYPE ASS'Y		
				angles	.XXX ±		product family	S.O.DIMM	code
					0° ±2°	MM	size	dwg no	sheet
				dr	CATHY LIN 02/13/95	scale	93764		5 of
				engr	V. CHUANG 02/13/95	1.5:1			
				chr	WAYNE YU 02/13/95	A4			
				appd	D K WANG 02/13/95				
sheet index	revision sheet						cage code		

Tous droits strictement réservés. Reproduction ou communication a des tiers interdite sous quelque forme que ce soit sans autorisation écrite du propriétaire. Propriété de c FCI. Droits de reproduction FCI.

All rights strictly reserved. Reproduction or issue to third parties in any form whatever is not permitted without written authority from the proprietor. Property of FCI. Copyright FCI.

PRODUCT NO.
93764-3****1

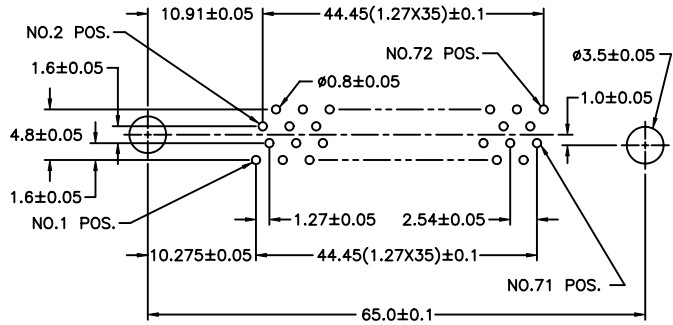

RECOMMENDED PCB LAYOUT

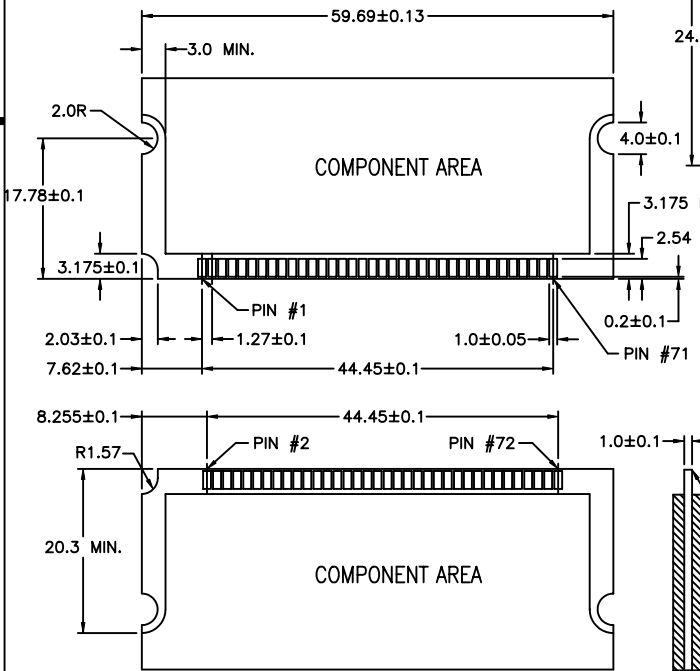

RECOMMENDED DIMM LAYOUT

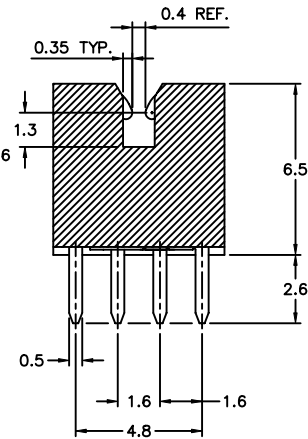
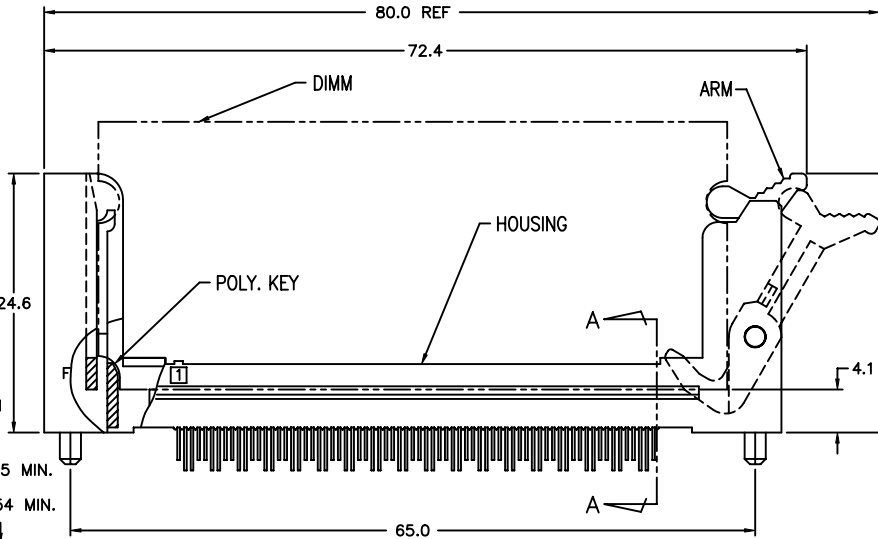
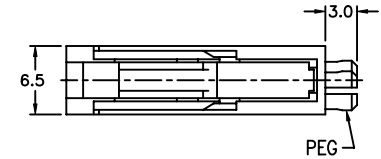
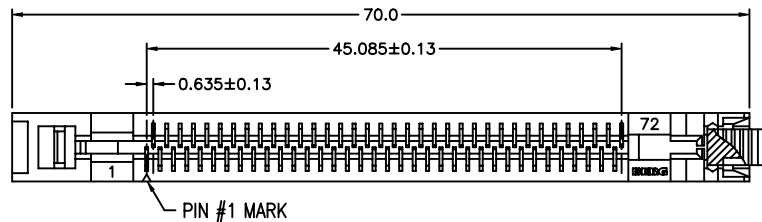

SECT. A-A
SCALE 5:1

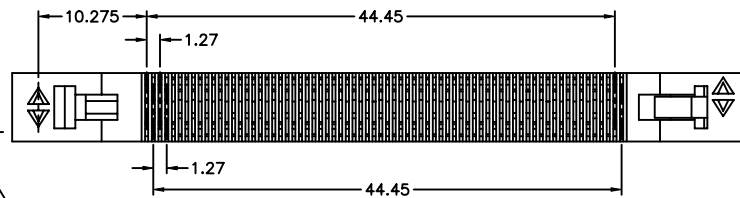

0.10 MAX. CHAMFER
RECOMMENDED
AT BOTH SIDES

CONFIDENTIAL

mat'l. code				tolerances unless otherwise specified		CUSTOMER COPY		 www.fciconnect.com	
ltr	ecn no	dr	date	linear	.X ± 0.20	projection	title		
T					.XX ± 0.10		SMALL OUTLINE DIMM SOCKET		
				angles	.XXX ±		VERTICAL TYPE ASS'Y		
					0° ±2°	MM	product family	S.O.DIMM	code
				dr	CATHY LIN	02/13/95	size	dwg no	-
				enr	V. CHUANG	02/13/95	scale	1.5:1	sheet
				chr	WAYNE YU	02/13/95	A4	93764	6 of
				appd	D K WANG	02/13/95			
sheet index	revision sheet								

PRODUCT NO.
93764-4****2

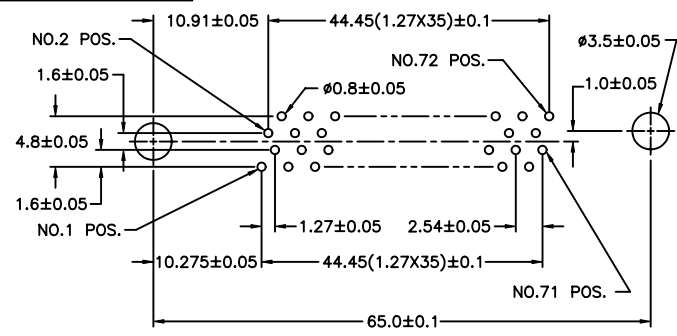

RECOMMENDED PCB LAYOUT

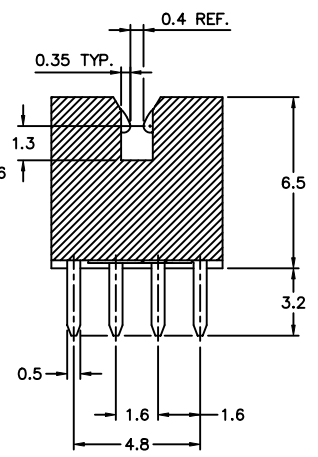
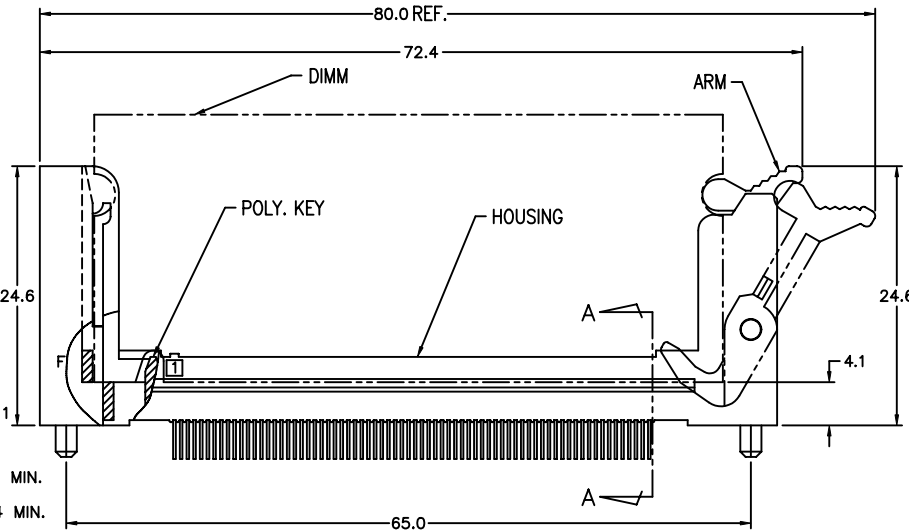
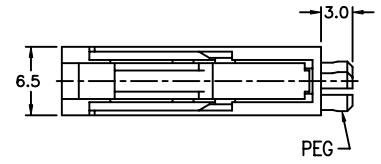
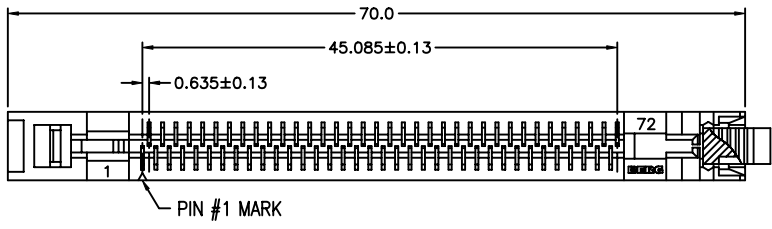

SECT. A-A
SCALE 5:1

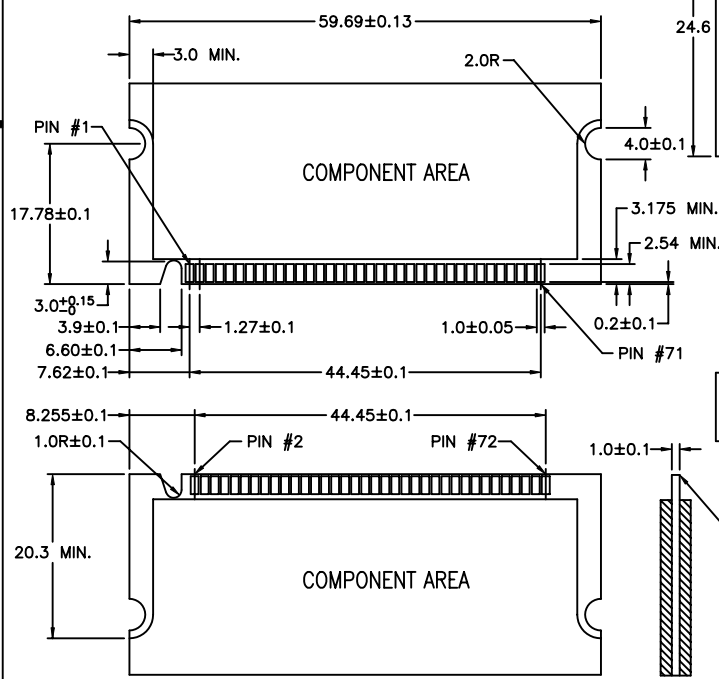

RECOMMENDED DIMM LAYOUT

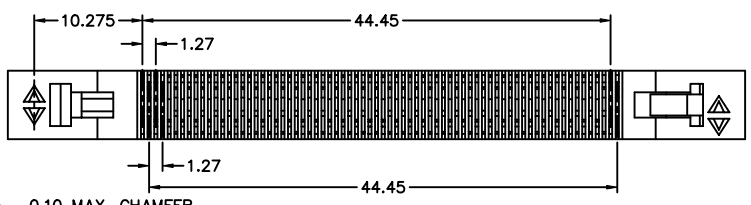

CONFIDENTIAL

mat'l. code				tolerances unless otherwise specified		CUSTOMER COPY		 www.fciconnect.com	
ltr	ecn no	dr	date	linear	.X ± 0.20	projection	title		
T					.XX ± 0.10		SMALL OUTLINE DIMM SOCKET		
				angles	.XXX ±	MM	VERTICAL TYPE ASS'Y		
					0° ±2°	scale	product family	S.O.DIMM	code
				dr	CATHY LIN	02/13/95	size	dwg no	-
				enr	V. CHUANG	02/13/95	scale	1.5:1	sheet
				chr	WAYNE YU	02/13/95	A4	93764	7 of
				appd	D K WANG	02/13/95			
sheet index	revision sheet								

Tous droits strictement reserves. Reproduction ou communication a des tiers interdite sous quelque forme que ce soit sans autorisation ecrite du proprietaire. Propriete de c FCI. Droits de reproduction FCI.

All rights strictly reserved. Reproduction or issue to third parties in any form whatever is not permitted without written authority from the proprietor. Property of FCI. Copyright FCI.

Tous droits strictement réservés. Reproduction ou communication a des tiers interdite sous quelque forme que ce soit sans autorisation écrite du propriétaire. Propriete de c FCI. Droits de reproduction FCI.

All rights strictly reserved. Reproduction or issue to third parties in any form whatever is not permitted without written authority from the proprietor. Property of FCI. Copyright FCI.

PRODUCT NO.
93764-51***1

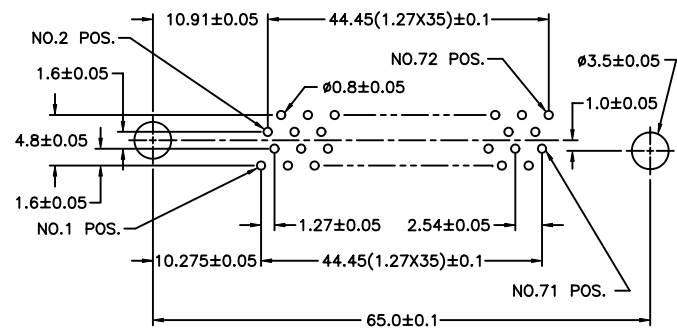

RECOMMENDED PCB LAYOUT

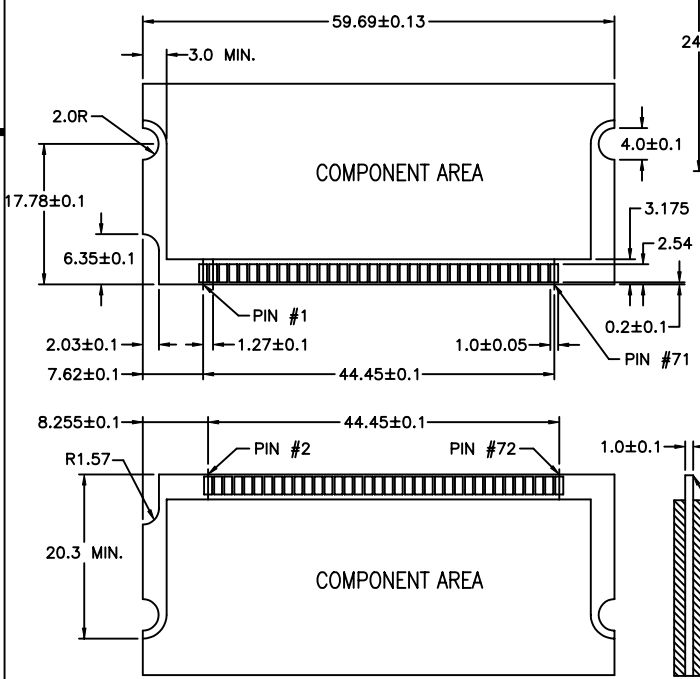

RECOMMENDED DIMM LAYOUT

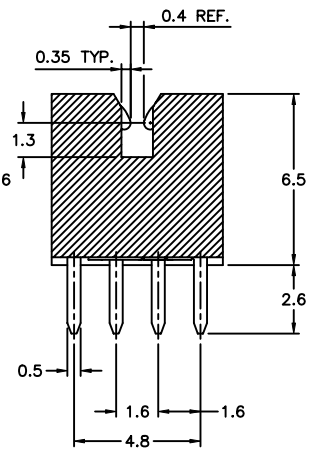
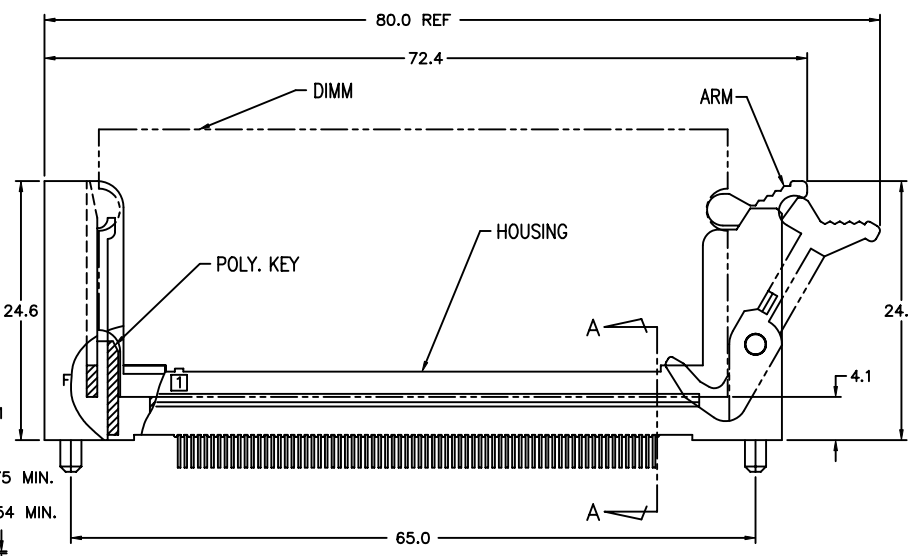
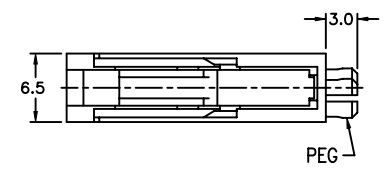
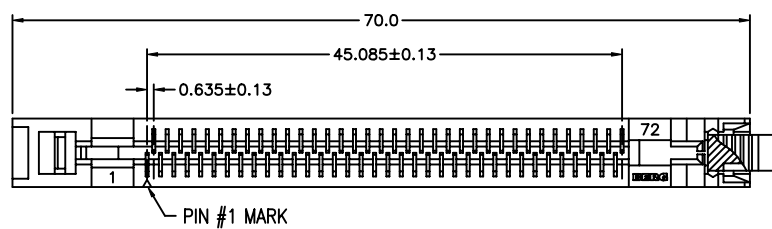

SECT. A-A
SCALE 5:1

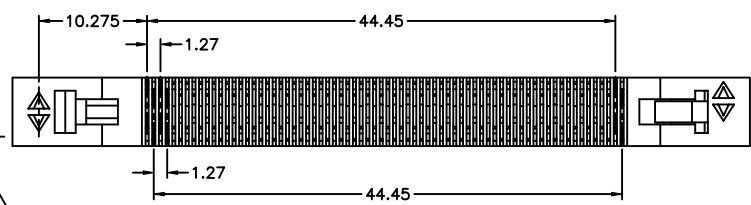

CONFIDENTIAL

mat'l. code				tolerances unless otherwise specified		CUSTOMER COPY		FCI www.fciconnect.com	
ltr	ecn no	dr	date	linear	.X ± 0.20	projection	title		
T					.XX ± 0.10		SMALL OUTLINE DIMM SOCKET VERTICAL TYPE ASS'Y		
				angles	.XXX ±		product family	S.O.DIMM	code
					0° ±2°	MM	size	dwg no	
		dr	CATHY LIN	02/13/95		scale	93764		
		enr	V. CHUANG	02/13/95		1.5:1	sheet 8 of		
		chr	WAYNE YU	02/13/95					
		appd	D K WANG	02/13/95					
sheet index	revision sheet						cage code		

Tous droits strictement réservés. Reproduction ou communication a des tiers interdite sous quelque forme que ce soit sans autorisation écrite du propriétaire. Propriete de c FCI. Droits de reproduction FCI.

All rights strictly reserved. Reproduction or issue to third parties in any form whatever is not permitted without written authority from the proprietor. Property of FCI. Copyright FCI.

PRODUCT NO.
93764-51***2

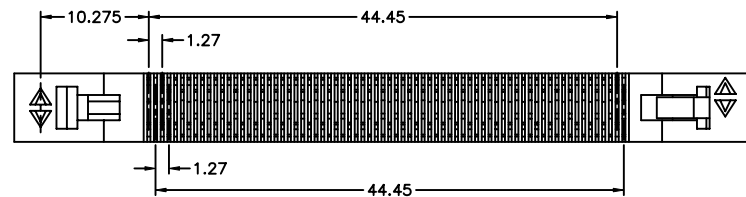
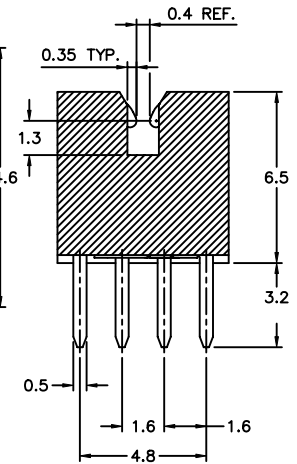
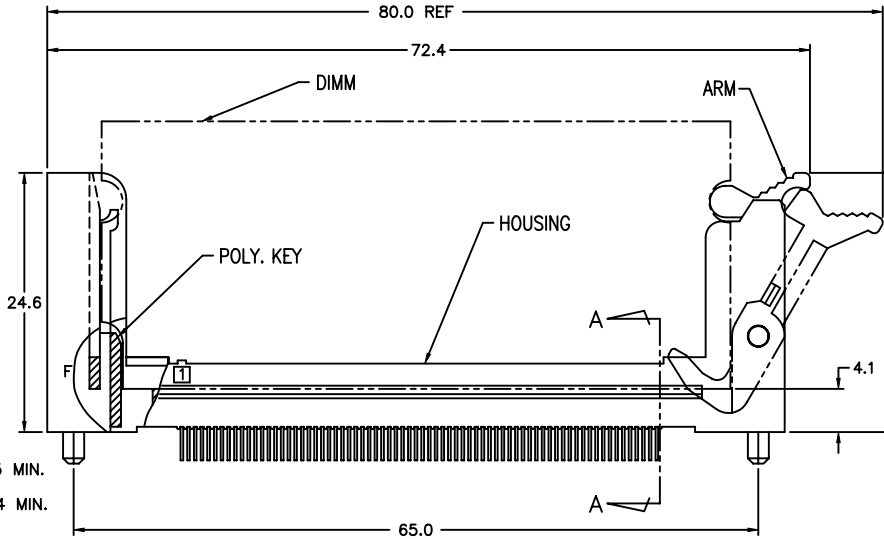
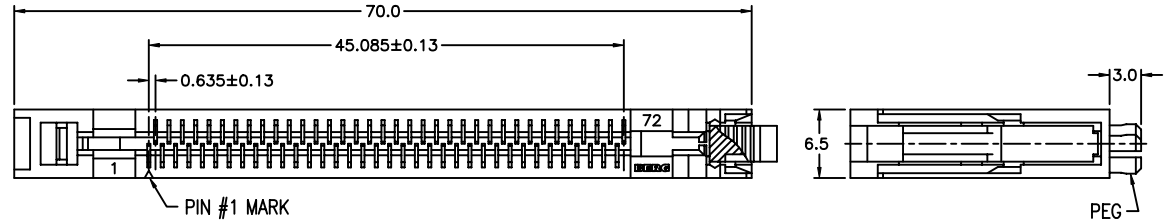
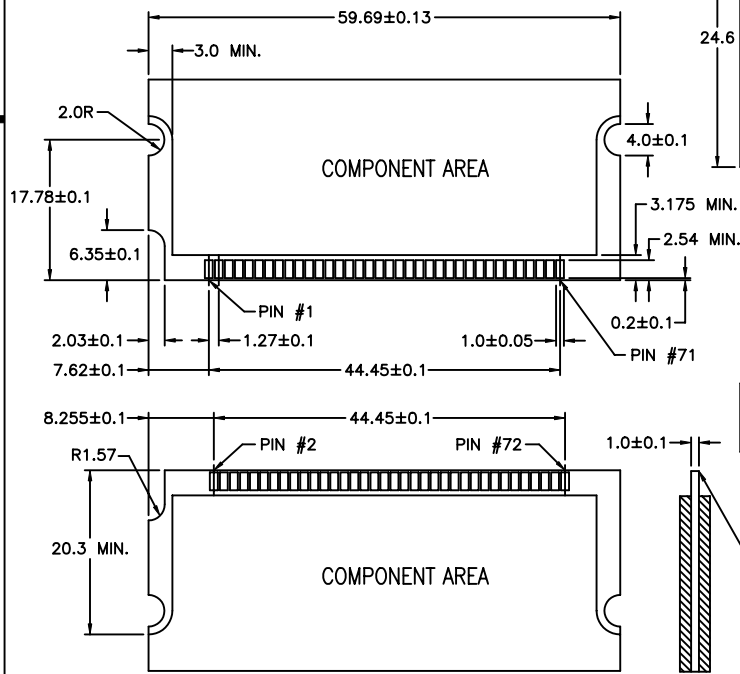
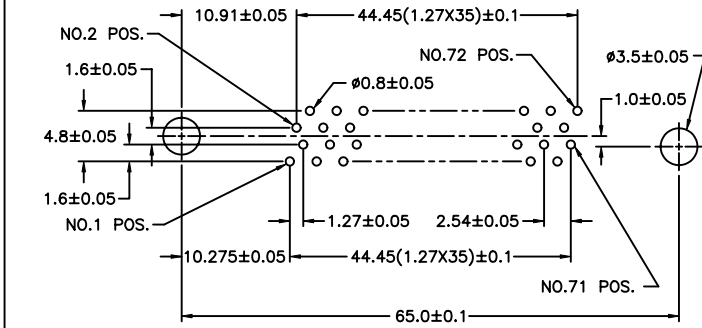

CONFIDENTIAL

mat'l. code		tolerances unless otherwise specified		CUSTOMER COPY		FCI www.fciconnect.com		
ltr	ecn no	dr	date	linear	.X ± 0.20	projection	title	
T					.XX ± 0.10		SMALL OUTLINE DIMM SOCKET VERTICAL TYPE ASS'Y	
				angles	.XXX ±		product family	S.O.DIMM
					0° ±2°	scale	code	
				dr	CATHY LIN	02/13/95	—	
				enr	V. CHUANG	02/13/95	size	dwg no
				chr	WAYNE YU	02/13/95	93764	sheet
				appd	D K WANG	02/13/95	1.5:1	9 of
sheet index	revision sheet							

Tous droits strictement reserves. Reproduction ou communication a des tiers interdite sous quelque forme que ce soit sans autorisation ecrite du proprietaire. Propriete de c FCI. Droits de reproduction FCI.

All rights strictly reserved. Reproduction or issue to third parties in any form whatever is not permitted without written authority from the proprietor. Property of FCI. Copyright FCI.

PRODUCT NO.
93764-1****
93764-2****

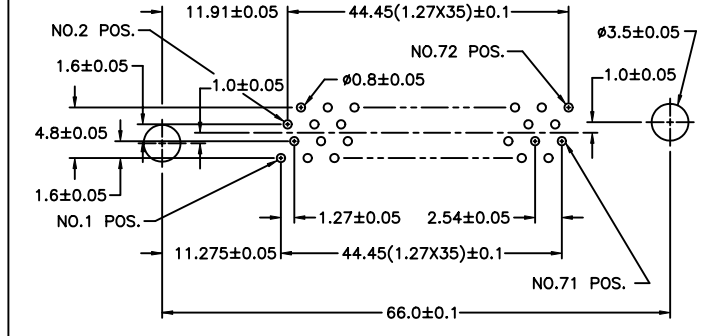

RECOMMENDED PCB LAYOUT

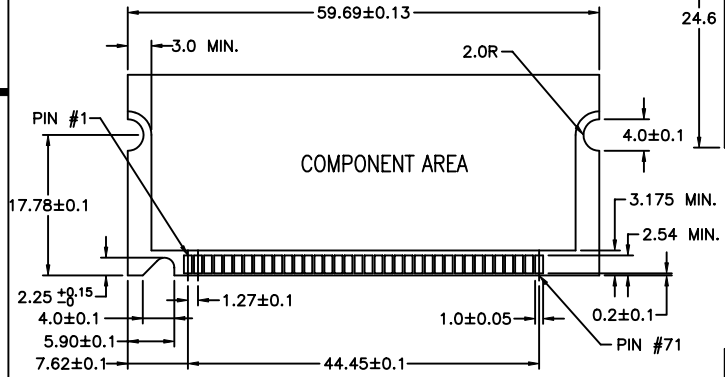

RECOMMENDED DIMM LAYOUT

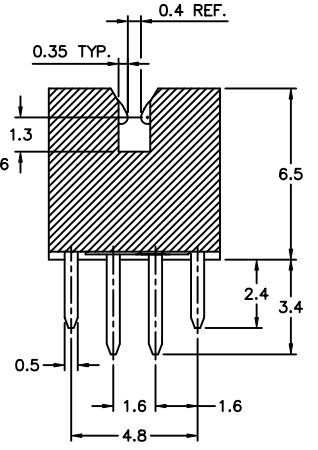
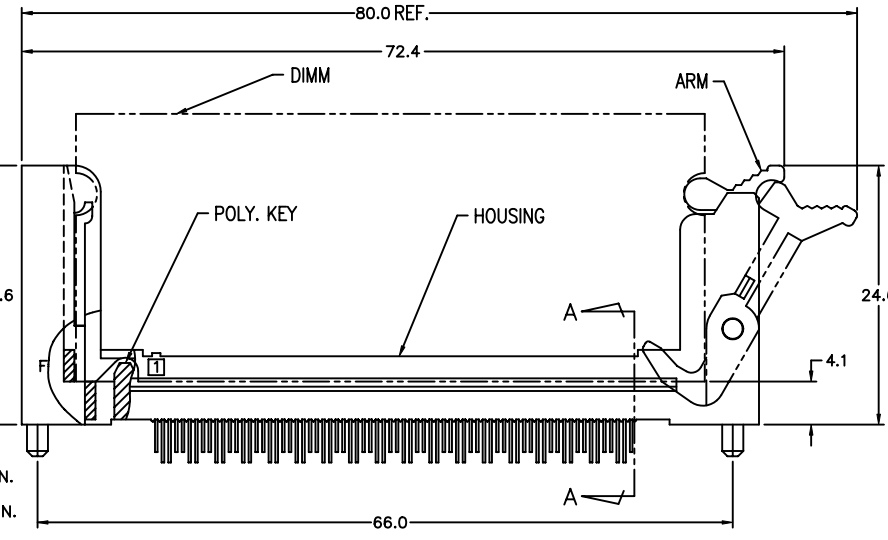
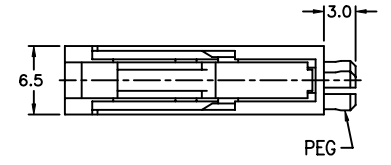
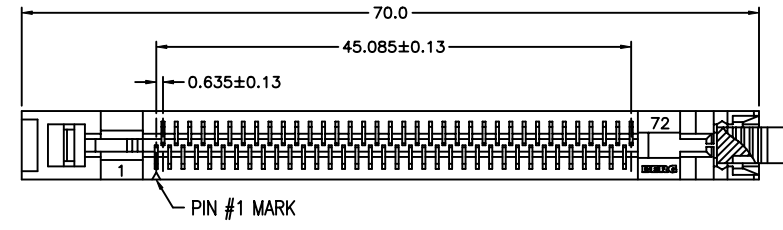

SECTION A-A
SCALE 5:1

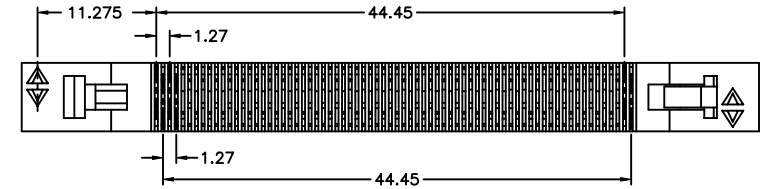

CONFIDENTIAL

mat'l. code		tolerances unless otherwise specified		CUSTOMER COPY		FCI		www.fciconnect.com	
ltr	ecn no	dr	date	linear	.X ± 0.20	projection	title		
T					.XX ± 0.10		SMALL OUTLINE DIMM SOCKET		
				angles	.XXX ±		VERTICAL TYPE ASS'Y		
					0° ±2°	MM	product family	S.O.DIMM	code
				dr	CATHY LIN	02/13/95	size	dwg no	-
				engr	V. CHUANG	02/13/95	scale	1.5:1	sheet
				chr	WAYNE YU	02/13/95	A4	93764	10 of
				appd	D K WANG	02/13/95			
sheet index	revision sheet								

PRODUCT NO.
93764-52***2

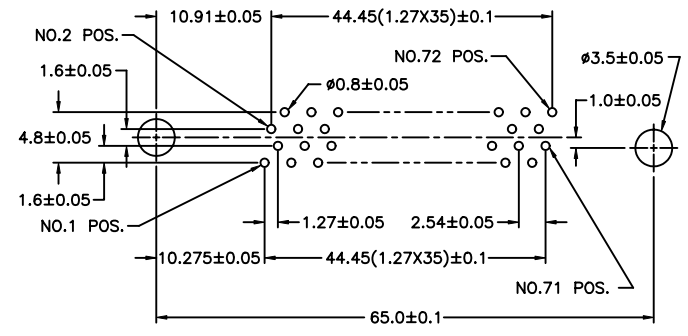

RECOMMENDED PCB LAYOUT

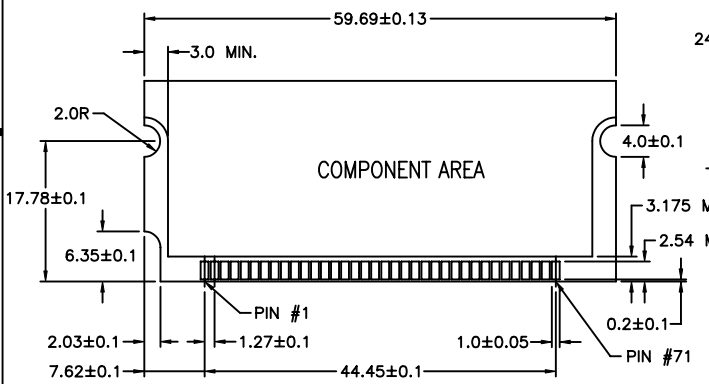

RECOMMENDED DIMM LAYOUT

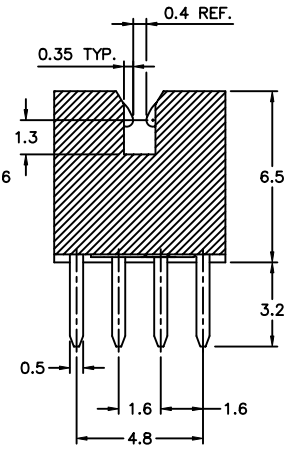
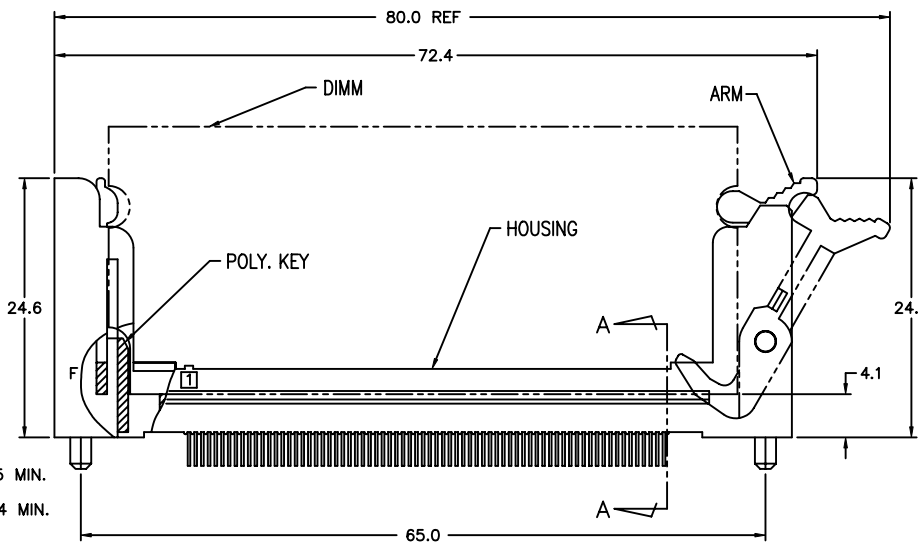
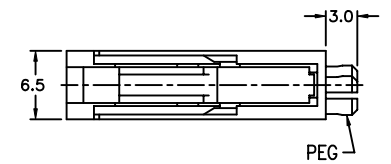
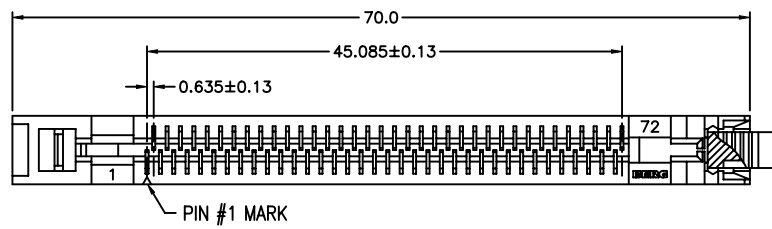

SECTION A-A
SCALE 5:1

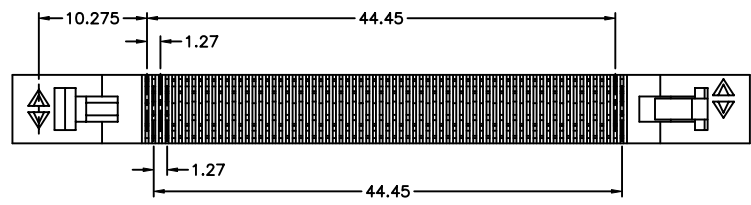

0.10 MAX. CHAMFER RECOMMENDED AT BOTH SIDES

CONFIDENTIAL

mat'l. code				tolerances unless otherwise specified		CUSTOMER COPY		 www.fciconnect.com	
ltr	ecn no	dr	date	linear	.X ± 0.20	projection	title		
T					.XX ± 0.10		SMALL OUTLINE DIMM SOCKET		
				angles	.XXX ±		VERTICAL TYPE ASS'Y		
					0° ±2°	MM	product family	S.O.DIMM	code
				dr	CATHY LIN	02/13/95	size	dwg no	-
				enr	V. CHUANG	02/13/95	scale	1.5:1	sheet
				chr	WAYNE YU	02/13/95	A4	93764	11 of
				appd	D K WANG	02/13/95			
sheet index	revision sheet								

Tous droits strictement reserves. Reproduction ou communication a des tiers interdite sous quelque forme que ce soit sans autorisation ecrite du proprietaire. Propriete de c FCI. Droits de reproduction FCI.

All rights strictly reserved. Reproduction or issue to third parties in any form whatever is not permitted without written authority from the proprietor. Property of FCI. Copyright FCI.

PRODUCT NO.
93764-*****

NOTE:

- MATERIAL: a. HOUSING--LCP, UL94V-0 RATED.
b. TERMINAL--PHOSPHOR BRONZE.
c. ARM--PPS OR LCP, UL94V-0 RATED.
- FINISH: TERMINAL--50μ"(MIN.) NICKEL UNDERPLATING OVERALL, 100μ"(MIN.) TIN/LEAD OR PURE TIN PLATING ON SOLDER LEG. AND 8μ"(MIN.) GOLD PLATING AT CONTACT AREA.
- PRODUCT SPECIFICATION: GS-12-065.
- THIS PRODUCT MEETS EUROPEAN UNION DIRECTIVES AND OTHER COUNTRY REGULATIONS AS DESCRIBED IN GS-22-008.
- THE HOUSING WILL WITHSTAND EXPOSURE TO 260° PEAK TEMPERATURE FOR 10 SECONDS IN A WAVE SOLDER APPLICATION.
- PROD. NO. DESCRIPTION:
93764-*****LF --- "LF" CODE ONLY EXIST WHEN 3RD PLATING CODE IS "9". EX:93764-81972LF.

TERMINAL TAIL DIM	
N/A	2.4/3.4
1	2.6
2	3.2

POSITION NO.
72: 72 POS.
PLATING:

	CONTACT AREA	SOLDER TAIL	
	GOLD	TIN-LEAD	100% TIN
8	8 u"	100 u"	----
9	8 u"	---	100 u"

PEG OPTION:
1: WITH PEG.
2: WITH PEG,BUMP ON LEFT SIDE.

STYLE:
1: GREEN HSG + GREEN ARM, FOR SPECIAL RAM.
2: NATURAL HSG + NATURAL ARM, FOR SPECIAL RAM.
3: NATURAL HSG + BLACK ARM, FOR 3.3V RAM.
4: NATURAL HSG + BLACK ARM, FOR SPECIAL 5.0V ROM.
5: BLACK HSG + BLACK ARM, FOR 5.0V RAM.
6: BLACK HSG + BLACK ARM, FOR 3.3V RAM.
7: NATURAL HSG + BROWN ARM, FOR SPECIAL 3.3V ROM.
8: BLACK HSG + BROWN ARM, FOR 3.3V RAM.

93764-81*72	FOR 3.3V RAM	BLACK	BROWN
93764-71*72	FOR 3.3V ROM	NATURAL IVORY	BROWN
93764-61*72	FOR 3.3V RAM	BLACK	BLACK
93764-52*722	FOR 5.0V RAM	BLACK	BLACK
93764-51*722	FOR 5.0V RAM	BLACK	BLACK
93764-51*721	FOR 5.0V RAM	BLACK	BLACK
93764-51*72	FOR 5.0V RAM	BLACK	BLACK
93764-51*72	FOR 5.0V RAM	BLACK	BLACK
93764-41*722	FOR 5.0V ROM	NATURAL IVORY	BLACK
93764-41*72	FOR 5.0V ROM	NATURAL IVORY	BLACK
93764-31*721	FOR 3.3V RAM	NATURAL IVORY	BLACK
93764-31*72	FOR 3.3V RAM	NATURAL IVORY	BLACK
93764-21*72	FOR SPECIAL RAM	NATURAL IVORY	NATURAL IVORY
93764-11*72	FOR SPECIAL RAM	GREEN	GREEN
PROD. NO.	STYLE	HSG COLOR	ARM COLOR

CONFIDENTIAL

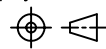
mat'l. code		tolerances unless otherwise specified		CUSTOMER COPY	 www.fciconnect.com
ltr	ecn no	dr	date	projection	
U				linear	 title SMALL OUTLINE DIMM SOCKET VERTICAL TYPE ASS'Y
				angles	
				dr	
				enr	product family
				chr	S.O.DIMM
				appd	code
					size
					dwg no
				scale	93764
				1:1	sheet
sheet	revision				12 of
index	sheet				

Tous droits strictement reserves. Reproduction ou communication a des tiers interdite sous quelque forme que ce soit sans autorisation ecrite du proprietaire. Propriete de c FCI. Droits de reproduction FCI.

All rights strictly reserved. Reproduction or issue to third parties in any form whatever is not permitted without written authority from the proprietor. Property of FCI. Copyright FCI.